

Applications

The EZHANGER is a dual point hanger with a caddy hanger, grip fastener and crimped loop ends. It is meant for indoor applications where an easy-to-install cable hanger is needed to mount a luminaire. The EZHANGER is NOT suitable for use in chlorinated/swimming pool environments.

Features

- Caddy Hanger fits through holes on the back of luminaire
- Galvanized high tensile steel cable to EN12385
- 15 foot overall length
- Zinc plated steel toggle
- ROHS compliant
- Cable Diameter (in.): 5/64
- Strand configuration: 7x7
- Min. breaking load (lbs): 500
- Max. safe working load (lbs): 100
- Tensile strength (lbs/sq. in.): 256,700

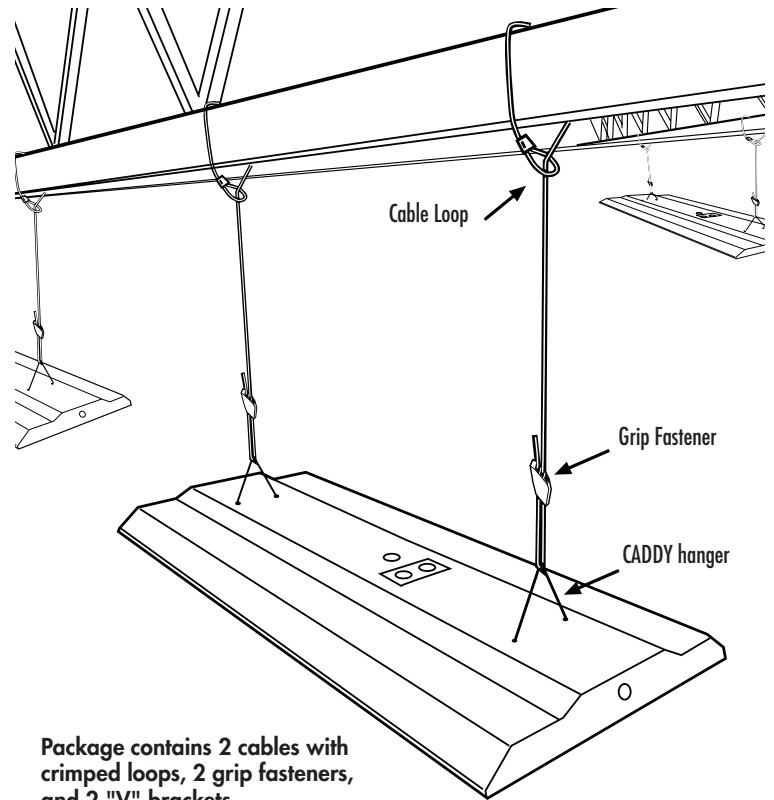

Dimensions

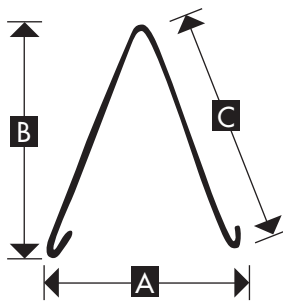

Size	A (in.)	B (in.)	C (in.)
	4.75"	5.125"	5.5"

Application Examples

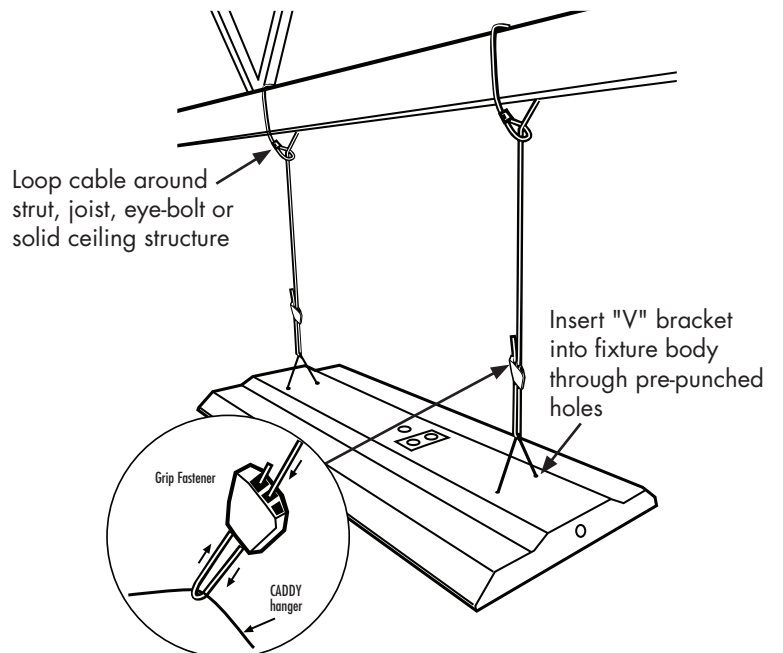

Feed cable through grip fastener and adjust to desired mounting height

Specifications and dimensions subject to change without notice.